

January 2021

QIAamp[®] DSP Viral RNA Mini Kit Instructions for Use (Handbook)



Version 1



For In Vitro Diagnostic Use



61904



QIAGEN GmbH, QIAGEN Strasse 1, D-40724 Hilden
Tel: +49-2103-29-0



1122786



Contents

Intended Use	5
Description and Principle	6
Adsorption to the QIAamp membrane	8
Removal of residual contaminants	8
Elution with Buffer AVE	8
Cellular DNA contamination	8
Sample volumes	9
Lysis	9
Carrier RNA	9
Addition of internal controls	10
Spin and vacuum procedures	10
Automated viral RNA purification on the QIAcube/QIAcube Connect MDx	11
Summary and explanation	13
Materials Provided	14
Kit contents	14
Materials Required but Not Provided	15
Warnings and Precautions	17
Safety information	17
Reagent Storage and Handling	20
Specimen Storage and Handling	20
Procedure	21
Important points before starting	21

Preparation of reagents and buffers	22
Handling of QIAamp Mini spin columns.....	26
Setup of the QIAvac 24 Plus vacuum manifold.....	29
Centrifugation	30
Protocol: Sample concentration	31
Protocol: Purification of viral RNA using a microcentrifuge or the QIAcube/QIAcube Connect MDx.....	32
Protocol: Purification of viral RNA (vacuum protocol)	35
Quality Control.....	38
Limitations.....	38
Symbols.....	39
Contact Information	41
Appendix	42
Ordering Information	45
Document Revision History.....	47

Intended Use

The QIAamp DSP Viral RNA Mini Kit is a system that uses silica-membrane technology (QIAamp technology) for isolation and purification of viral RNA from biological specimens.

The product is intended to be used by professional users, such as technicians and physicians that are trained in molecular biological techniques.

The QIAamp DSP Viral RNA Mini Kit is intended for in vitro diagnostic use.

Description and Principle

The QIAamp DSP Viral RNA Mini Kit represents a well-established technology for viral RNA preparation. The kit combines the selective binding properties of a silica gel-based membrane with the speed of spin or vacuum technology and is suited for simultaneous processing of multiple samples. QIAamp DSP Viral RNA spin protocols can be automated on the QIAcube® and the QIAcube Connect MDx.

The sample is first lysed under highly denaturing conditions to inactivate RNases and to ensure isolation of intact viral RNA. Buffering conditions are then adjusted to provide optimal binding of the RNA to the QIAamp membrane, and the sample is loaded onto the QIAamp Mini spin column. The RNA binds to the membrane, and contaminants are efficiently washed away in two steps using two different wash buffers. High-quality RNA is eluted in a special RNase-free buffer, ready for direct use or safe storage.

The special QIAamp membrane provides high recovery of pure, intact RNA in just 20 minutes without the use of phenol/chloroform extraction or alcohol precipitation.

All buffers and reagents are guaranteed to be RNase-free.

Automatable on the QIAcube/QIAcube Connect MDx

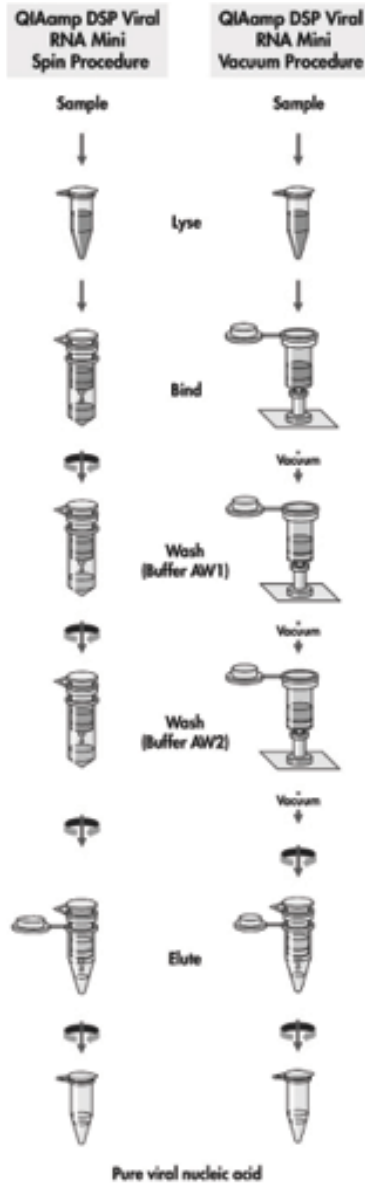

Adsorption to the QIAamp membrane

The buffering conditions of the lysate must be adjusted to provide optimal binding conditions for the viral RNA before loading the sample onto the QIAamp Mini spin column. Due to the large volume of lysate, it will be necessary to load the lysate onto the QIAamp Mini spin column in multiple steps. Viral RNA is adsorbed onto the QIAamp silica membrane during two brief centrifugation steps or by vacuum. Salt and pH conditions in the lysate ensure that protein and other contaminants, which can inhibit downstream enzymatic reactions, are not retained on the QIAamp membrane.

Removal of residual contaminants

Viral RNA, bound to the QIAamp membrane, is washed of contaminants during two short centrifugation or vacuum steps. The use of two different wash buffers, AW1 and AW2, significantly improves the purity of the eluted RNA. Optimized wash conditions ensure efficient removal of any residual contaminants without affecting RNA binding.

Elution with Buffer AVE

Buffer AVE is RNase-free water that contains 0.04% sodium azide to prevent microbial growth and subsequent contamination with RNases. Sodium azide affects spectrophotometric absorbance readings between 220 and 280 nm but has no effect on downstream applications, such as RT-PCR. Should you wish to determine the purity of the eluted RNA, we recommend calibrating the spectrophotometer with Buffer AVE prior to measuring absorbance.

Cellular DNA contamination

The QIAamp DSP Viral RNA Mini Kit is not designed to separate viral RNA from cellular DNA, and both will be purified in parallel if present in the sample. To avoid co-purification of cellular DNA, the use of cell-free body fluids for preparation of viral RNA is recommended. Samples containing cells, such as cerebrospinal fluid, bone marrow, urine, and most swabs, should first

be filtered, or centrifuged for 10 minutes at approximately 1500 x *g* and the supernatant used. If RNA and DNA have been isolated in parallel, the eluate can be digested with DNase using RNase-free DNase, followed by heat treatment (15 minutes ± 1 minute, 70°C ± 3°C) to inactivate the DNase.

Sample volumes

The QIAamp DSP Viral RNA procedure is optimized for use with 140 µl samples. Small samples should be adjusted to 140 µl with phosphate-buffered saline (PBS) before loading, and samples with a low viral titer should be concentrated to 140 µl before processing. See “Protocol: Sample concentration”, page 31.

Lysis

The sample is first lysed under the highly denaturing conditions provided by Buffer AVL to inactivate RNases and to ensure isolation of intact viral RNA. Carrier RNA, added to Buffer AVL, improves the binding of viral RNA to the QIAamp membrane especially in the case of low-titer samples, and limits possible degradation of the viral RNA due to any residual RNase activity.

Carrier RNA

Carrier RNA serves two purposes. Firstly, it enhances binding of viral nucleic acids to the QIAamp Mini spin column membrane, especially if there are very few target molecules in the sample. Secondly, the addition of large amounts of carrier RNA reduces the chance of viral RNA degradation in the rare event that RNase molecules escape denaturation by the chaotropic salts and detergent in Buffer AVL. If carrier RNA is not added to Buffer AVL, this may lead to reduced viral RNA recovery.

The amount of lyophilized carrier RNA provided is sufficient for the volume of Buffer AVL supplied with the kit. The concentration of carrier RNA has been adjusted so that the QIAamp

DSP Viral RNA Mini Kit can be used as a generic purification system compatible with many different amplification systems and is suitable for a wide range of RNA viruses.

Different amplification systems vary in efficiency depending on the total amount of nucleic acid present in the reaction. Eluates from this kit contain both viral nucleic acids and carrier RNA, and amounts of carrier RNA will greatly exceed amounts of viral nucleic acids. Calculations of how much eluate to add to downstream amplifications should therefore be based on the amount of carrier RNA added. To obtain the highest levels of sensitivity in amplification reactions, it may be necessary to adjust the amount of carrier RNA added to Buffer AVL.

Addition of internal controls

When using the QIAamp DSP Viral RNA Mini protocols in combination with commercially available amplification systems, the introduction of an internal control into the purification procedure is highly recommended to ensure reliable test results. Internal control RNA or DNA should be added together with the carrier RNA to the lysis buffer. For optimal purification efficiency, internal control molecules should be longer than 200 nucleotides, as smaller molecules are not efficiently recovered.

Refer to the manufacturer's instructions in order to determine the optimal concentration. Using a concentration other than that recommended may reduce amplification efficiency.

Spin and vacuum procedures

The QIAamp DSP Viral RNA Mini purification procedure is carried out in three steps using QIAamp Mini spin columns in a standard microcentrifuge, on a vacuum manifold, or on the QIAcube. The procedures are designed to ensure that there is no sample-to-sample cross-contamination and allow safe handling of potentially infectious samples.

QIAamp Mini spin columns fit into most standard microcentrifuge tubes. In the spin protocol, due to the volume of filtrate, 2 ml wash tubes (WT) (provided) are required to support the

QIAamp Mini spin column during loading and wash steps. For the vacuum protocol, a vacuum manifold (QIAvac 24 Plus or equivalent; see page 15) and a vacuum pump capable of producing a vacuum of –800 to –900 mbar (e.g., QIAGEN® Vacuum Pump) are required.

Eluted RNA can be collected in standard 1.5 ml microcentrifuge tubes (provided). These tubes must be RNase-free to avoid degradation of viral RNA by RNases.

Automated viral RNA purification on the QIAcube/QIAcube Connect MDx

The QIAcube and QIAcube Connect MDx perform automated isolation and purification of nucleic acids. It can process of up to 12 samples per single run.

If automating the QIAamp DSP Viral RNA Mini Kit on the QIAcube or on the QIAcube Connect MDx, the instrument may process fewer than 50 samples due to dead volumes, evaporation, and additional reagent consumption by automated pipetting. QIAGEN only guarantees 50 sample preps with manual use of the QIAamp DSP Viral RNA Mini Kit.



Figure 1. The QIAcube.



Figure 2. The QIAcube Connect MDx.

Summary and explanation

The QIAamp DSP Viral RNA Mini Kit provides the method to purify viral RNA for reliable use in amplification technologies. Viral RNA can be purified from plasma (treated with anticoagulants other than heparin), serum, and other cell-free body fluids.

Materials Provided

Kit contents

QIAamp DSP Viral RNA Mini Kit			(50)
Catalog no.			61904
Number of preps			50†
QIAamp Mini Spin	QIAamp Mini Spin Columns with Wash Tubes	COL	50
ET	Elution Tubes (1.5 ml)	ELU TUBE	50
LT	Lysis Tubes (2 ml)	LYS TUBE	50
WT	Wash Tubes (2 ml)	WASH TUBE	4 x 50
AVL	Buffer AVL*	VIR LYS BUF	31 ml
AW1	Buffer AW1* (concentrate)	WASH BUF 1 CONC	19 ml
AW2	Buffer AW2† (concentrate)	WASH BUF 2 CONC	13 ml
AVE	Buffer AVE†	ELU BUF	3 x 2 ml
Carrier	Carrier RNA (poly A)	CAR RNA	310 µg
–	Instructions for Use (Handbook)		1

* Contains chaotropic salt. Not compatible with disinfectants containing bleach. See page 17 for warnings and precautions.

† Contains sodium azide as a preservative.

‡ If automating the QIAamp DSP Viral RNA Mini Kit on the QIAcube or QIAcube Connect MDx instrument, the instrument may process fewer than 50 samples due to dead volumes, evaporation, and additional reagent consumption by automated pipetting. QIAGEN only guarantees 50 sample preps with manual use of the QIAamp DSP Viral RNA Mini Kit.

Materials Required but Not Provided

When working with chemicals, always wear a suitable lab coat, disposable gloves, and protective goggles. For more information, consult the appropriate safety data sheets (SDSs), available from the product supplier.

- Ethanol (96–100%)*
- 1.5 ml microcentrifuge tubes
- Sterile, RNase-free pipettes†
- Sterile, RNase-free pipette tips (to avoid cross-contamination, we recommend pipette tips with aerosol barriers)
- Microcentrifuge† (with rotor for 1.5 ml and 2 ml tubes)

For vacuum protocols

- QIAvac 24 Plus vacuum manifold (cat. no. 19413) or equivalent
- VacConnectors (cat. no. 19407)
- Vacuum Regulator (cat. no. 19530) for easy monitoring of vacuum pressures and easy releasing of vacuum
- Vacuum Pump (cat. no. 84010 or equivalent pump capable of producing a vacuum of –800 to –900 mbar)
- Optional: VacValves (cat. no. 19408)
- Optional: QIAvac Connecting System (cat. no. 19419)

* Do not use denatured alcohol, which contains other substances such as methanol or methylethylketone.

† To ensure that samples are properly processed in the QIAamp DSP Viral RNA Mini Kit procedures, we strongly recommend that instruments (e.g., microcentrifuges) are calibrated according to the manufacturers' recommendations.

For the automated procedure only

- Rotor Adapters, cat. no. 990394
- Rotor Adapter Holder, cat. no. 990392
- Sample Tubes CB (2 ml), cat. no. 990382 (sample input tube)
- Shaker Rack Plugs, cat. no. 9017854
- Reagent Bottles, 30 ml, cat. no. 990393
- Filter-Tips, 1000 µl, cat. no. 990352

Warnings and Precautions

Please be aware that you may be required to report serious incidents that have occurred in relation to the device to the manufacturer and the regulatory authority in which the user and/or the patient is established.

Safety information

For In Vitro Diagnostic Use

When working with chemicals, always wear a suitable lab coat, disposable gloves, and protective goggles. For more information, please consult the appropriate safety data sheets (SDSs). These are available online in convenient and compact PDF format at www.qiagen.com/safety where you can find, view, and print the SDS for each QIAGEN kit and kit component.

RNA is extremely sensitive to RNases and should always be prepared with due care. Hands and dust particles may carry bacteria and molds and are the most common sources of RNase contamination. Please read "Handling RNA" in the Appendix (page 42) of this handbook before starting.

PCR should always be carried out using good laboratory practices. Accordingly, a PCR laboratory should always be divided into three areas: an area for preparation of reagents, an area for preparation of samples, and an area for amplification and detection. Due to the high sensitivity of PCR, it is absolutely necessary that all reagents remain pure and uncontaminated, and should be monitored carefully and routinely. Contaminated reagents must be discarded.



CAUTION: DO NOT add bleach or acidic solutions directly to Buffer AVL or Buffer AW1.

Buffers AVL and AW1 contain guanidine salts, which can form highly reactive compounds when combined with bleach. If liquid containing these buffers is spilt, clean with suitable laboratory detergent and water. If the spilt liquid contains potentially infectious agents, clean the affected area first with laboratory detergent and water, and then with 1% (v/v) sodium hypochlorite.

If the buffer bottles are damaged or leaking, wear gloves and protective goggles when discarding the bottles in order to avoid personal injury or injury to others.

QIAGEN has not tested the liquid waste generated by the QIAamp DSP Viral RNA Mini procedures for residual infectious materials. Contamination of the liquid waste with residual infectious materials is highly unlikely, but cannot be excluded completely. Therefore, liquid waste must be considered infectious and be handled and discarded according to local safety regulations.

The following hazard and precautionary statements apply to components of QIAamp DSP Viral RNA Mini Kit:

Buffer AVL



Contains: guanidine thiocyanate. Danger! Harmful in contact with skin or if inhaled. May be harmful if swallowed. Causes severe skin burns and eye damage. Harmful to aquatic life with long lasting effects. Contact with acids liberates very toxic gas. Dispose of contents/container to an approved waste disposal plant. IF IN EYES: Rinse cautiously with water for several minutes. Remove contact lenses, if present and easy to do. Continue rinsing. Take off contaminated clothing and wash it before reuse. IF ON SKIN (or hair): Remove/take off immediately all contaminated clothing. Rinse skin with water/shower. Immediately call a POISON CENTER or doctor/physician. Store locked up. Wear protective gloves/protective clothing/eye protection/face protection.

Buffer AW1



Contains: guanidine hydrochloride. Warning! Harmful if swallowed or if inhaled. Causes skin irritation. Causes serious eye irritation. Call a POISON CENTER or doctor/physician if you feel unwell. Dispose of contents/container to an approved waste disposal plant. Take off contaminated clothing and wash it before reuse. Wear protective gloves/protective clothing/eye protection/face protection.

Reagent Storage and Handling

QIAamp Mini spin columns should be stored dry at 2–8°C; storage at higher temperatures should be avoided. All solutions should be stored at room temperature (15–25°C) unless otherwise stated. QIAamp Mini spin columns and all buffers and reagents can be stored under these conditions until the expiration date on the kit box without showing any reduction in performance.

Lyophilized carrier RNA can be stored at room temperature until the expiration date on the kit box. Carrier RNA should be dissolved in Buffer AVE; for the manual procedure, dissolved carrier RNA should be immediately added to Buffer AVL as described on page 22. This solution should be prepared fresh, and is stable at 2–8°C for up to 48 hours. Buffer AVL–carrier RNA develops a precipitate when stored at 2–8°C that must be redissolved by warming at 80°C ± 3°C before use. Unused portions of carrier RNA dissolved in Buffer AVE should be frozen in aliquots at –30 to –15°C. Do not freeze–thaw the aliquots of carrier RNA more than 3 times.

DO NOT warm Buffer AVL–carrier RNA solution more than 6 times. DO NOT incubate at 80°C for more than 5 minutes. Frequent warming and extended incubation will cause degradation of the carrier RNA, leading to reduced recovery of viral RNA and eventually to false negative RT-PCR results, particularly when low-titer samples are used.

Specimen Storage and Handling

After collection and centrifugation, plasma (untreated or treated with anticoagulants other than heparin) or serum can be stored at 2–8°C for up to 6 hours. For long-term storage, freezing at –80 to –20°C in aliquots is recommended. Frozen plasma or serum samples must not be thawed more than once. Repeated freezing and thawing leads to denaturation and precipitation of proteins, causing reduced viral titers and subsequently reduced yields of the isolated viral RNA. In addition, cryoprecipitates formed by freeze–thawing will cause clogging of the QIAamp membrane. If cryoprecipitates are visible, they can be pelleted by briefly

centrifuging at approximately $6800 \times g$ for 3 minutes \pm 30 seconds. The cleared supernatant should be removed, without disturbing the pellet, and processed immediately.

Procedure

Important points before starting

- After receiving the kit, check the kit components for damage. If the blister packs or the buffer bottles are damaged, contact QIAGEN Technical Services or your local distributor. In case of liquid spillage, refer to “Warnings and Precautions” (page 17). Do not use damaged kit components, since their use may lead to poor kit performance.
- Always use RNase-free equipment.
- Always change pipette tips between liquid transfers. To minimize cross-contamination, we recommend the use of aerosol-barrier pipette tips.
- All centrifugation steps are carried out at room temperature (15–25°C).
- Always use disposable gloves and regularly check that they are not contaminated with sample material. Discard gloves if they become contaminated.
- To minimize cross-contamination, open only one tube at a time.
- Do not use kit components from other kits with the kits you are currently using, unless the lot numbers are identical.
- Avoid microbial contamination of the kit reagents.
- To maximize safety from potentially infectious material, we recommend working under laminar airflow conditions until the samples are lysed.
- For automation, follow the instructions from the protocol sheets (QIAcube) or on the software screen (QIAcube Connect MDx) and refer to the appropriate user manuals (for the QIAcube and the QIAcube Connect MDx).
- This kit should only be used by personnel trained in in vitro diagnostic laboratory practice.

Important notes

Please take a few moments to read this handbook carefully before beginning your preparation. The comments within the QIAamp DSP Viral RNA Mini protocols, beginning on page 31, are particularly valuable.

If preparing RNA for the first time please read “Handling RNA” in the Appendix of this handbook (page 42). All steps of the QIAamp DSP Viral RNA Mini protocols should be performed quickly and at room temperature. The QIAamp DSP Viral RNA Mini procedure is not designed to separate RNA from DNA. To avoid cellular DNA contamination, follow the guidelines in “Cellular DNA contamination” on page 8 of this handbook. The QIAamp DSP Viral RNA Mini procedure isolates all RNA molecules larger than 200 nucleotides. Smaller RNA molecules will not bind quantitatively under the conditions used.

Preparation of reagents and buffers

- Addition of carrier RNA to Buffer AVL* (for the manual procedure only)
Add 310 µl Buffer AVE to the tube containing 310 µg lyophilized carrier RNA to obtain a solution of 1 µg/µl. Dissolve the carrier RNA thoroughly, divide it into conveniently sized aliquots, and store it at –25 to –15°C. Do not freeze–thaw the aliquots of carrier RNA more than 3 times.
- Check Buffer AVL for precipitate, and if necessary incubate at 80°C ± 3°C until the precipitate is dissolved. Calculate the volume of Buffer AVL–carrier RNA mix needed per batch of samples by selecting the number of samples to be simultaneously processed from Table 1 (page 24).

* Contains chaotropic salt. Take appropriate laboratory safety measures, and wear gloves when handling. Not compatible with disinfecting agents that contain bleach. See page 17 for safety information.

For larger numbers of samples, volumes can be calculated using the following sample calculation:

$$n \times 0.56 \text{ ml} = y \text{ ml}$$

$$y \text{ ml} \times 10 \text{ } \mu\text{l/ml} = z$$

where: n = number of samples to be processed simultaneously

y = calculated volume of Buffer AVL

z = volume of carrier RNA–Buffer AVE to add to Buffer AVL

Gently mix by inverting the tube 10 times. To avoid foaming, do not vortex.

Note: The sample-preparation procedure is optimized for 5.6 μg of carrier RNA per sample. If less carrier RNA has been shown to be better for your amplification system, transfer only the required amount of dissolved carrier RNA to the tubes containing Buffer AVL. (Use of less than 5.6 μg carrier RNA per sample must be validated for each particular sample type and downstream assay.)

Buffer AVL–carrier RNA should be prepared fresh, and is stable at 2–8°C for up to 48 hours. This solution develops a precipitate when stored at 2–8°C that must be redissolved by warming at 80°C \pm 3°C before use. Do not warm Buffer AVL–carrier RNA solution more than 6 times. Do not incubate at 80°C \pm 3°C for more than 5 minutes. Frequent warming and extended incubation will cause degradation of carrier RNA, leading to reduced recovery of viral RNA and eventually false negative RT-PCR results. This is particularly the case with low-titer samples.

For the automated procedure, the QIAcube/QIAcube connect MDx will perform the setup of the Buffer AVL–carrier RNA mix.

Table 1. Volumes (Vol.) of Buffer AVL and carrier RNA–Buffer AVE mix required for specific numbers (No.) of samples for the QIAamp DSP Viral RNA Mini procedure

No. samples	Vol. Buffer AVL (ml)	Vol. Carrier RNA AVE (µl)	No. samples	Vol. Buffer AVL (ml)	Vol Carrier RNA AVE (µl)
1	0.56	5.6	13	7.28	72.8
2	1.12	11.2	14	7.84	78.4
3	1.68	16.8	15	8.40	84.0
4	2.24	22.4	16	8.96	89.6
5	2.80	28.0	17	9.52	95.2
6	3.36	33.6	18	10.08	100.8
7	3.92	39.2	19	10.64	106.4
8	4.48	44.8	20	11.20	112.0
9	5.04	50.4	21	11.76	117.6
10	5.60	56.0	22	12.32	123.2
11	6.16	61.6	23	12.88	128.8
12	6.72	67.2	24	13.44	134.4

Buffer AW1 *

Buffer AW1 is supplied as a concentrate. Before using for the first time, add the appropriate amount of ethanol (96–100%) as indicated on the bottle and in Table 2. Buffer AW1 is stable for 6 months when stored closed at room temperature, but only until the kit expiration date.

Table 2. Preparation of Buffer AW1

Kit cat. no.	No. of preps	AW1 concentrate	Ethanol	Final volume
61904	50	19 ml	25 ml	44 ml

Buffer AW2†

Buffer AW2 is supplied as a concentrate. Before using for the first time, add the appropriate amount of ethanol (96–100%) to Buffer AW2 concentrate as indicated on the bottle and in Table 3.

Buffer AW2 is stable for 6 months when stored closed at room temperature, but only until the kit expiration date.

Table 3. Preparation of Buffer AW2

Kit cat. no.	No. of preps	AW2 concentrate	Ethanol	Final volume
61904	50	13 ml	30 ml	43 ml

* Contains chaotropic salt. Take appropriate laboratory safety measures, and wear gloves when handling. Not compatible with disinfecting agents that contain bleach. See page 17 for safety information.

† Contains sodium azide as a preservative.

Handling of QIAamp Mini spin columns

Due to the sensitivity of nucleic acid amplification technologies, the following precautions are necessary when handling QIAamp Mini spin columns to avoid cross contamination between sample preparations:

- Carefully apply the sample or solution to the QIAamp Mini spin column. Pipet the sample into the QIAamp Mini spin column without wetting the rim of the column.
- Always change pipette tips between liquid transfers. We recommend the use of aerosol-barrier pipette tips.
- Avoid touching the QIAamp Mini spin column membrane with the pipette tip.
- After all pulse-vortexing steps, briefly centrifuge the microcentrifuge tubes to remove drops from the inside of the lids.
- Open only one QIAamp Mini spin column at a time, and take care to avoid generating aerosols.
- Wear gloves throughout the entire procedure. In case of contact between gloves and sample, change gloves immediately.

Vacuum protocol on the QIAvac

The QIAvac 24 Plus is designed for fast and efficient vacuum processing of up to 24 QIAGEN spin columns in parallel. Samples and wash solutions are drawn through the column membranes by vacuum instead of centrifugation, providing greater speed and reduced hands-on time in purification procedures.

In combination with the QIAvac Connecting System (optional), the QIAvac 24 Plus can be used as a flow-through system. The sample flow-through is collected in a separate waste bottle.

For maintenance of the QIAvac 24 Plus, please refer to the handling guidelines in the *QIAvac 24 Plus Handbook*.

Guidelines for the QIAvac 24 Plus

- Always place the QIAvac 24 Plus on a secure bench top or work area. If dropped, the QIAvac 24 Plus manifold may crack.
- Always store the QIAvac 24 Plus clean and dry. For cleaning procedures see the *QIAvac 24 Plus Handbook*.
- The components of the QIAvac 24 Plus are not resistant to certain solvents (Table 4). If these solvents are spilled on the unit, rinse it thoroughly with water.
- To ensure consistent performance, do not apply silicone or vacuum grease to any part of the QIAvac 24 Plus manifold.
- Always use caution and wear safety glasses when working near a vacuum manifold under pressure.
- Contact QIAGEN Technical Services or your local distributor for information concerning spare or replacement parts.
- The vacuum pressure is the pressure differential between the inside of the vacuum manifold and the atmosphere (standard atmospheric pressure 1013 millibar or 760 mm Hg) and can be measured using the QIAvac Connecting System or a vacuum regulator (see Figure 3, page 28). The vacuum protocol requires a vacuum pump capable of producing a vacuum of –800 to –900 mbar (e.g., QIAGEN Vacuum Pump). Higher vacuum pressures must be avoided. Use of vacuum pressures lower than recommended may reduce DNA yield and purity and increase the frequency of clogged membranes.

Table 4. Chemical resistance properties of the QIAvac 24 Plus

Resistant to:		Not resistant to:
Acetic acid	Chaotropic salts	Benzene
Chromic acid	Concentrated alcohols	Phenol
SDS	Sodium chloride	Chloroform
Tween® 20	Urea	Toluene
Chlorine bleach	Hydrochloric acid	Ethers
Sodium hydroxide		

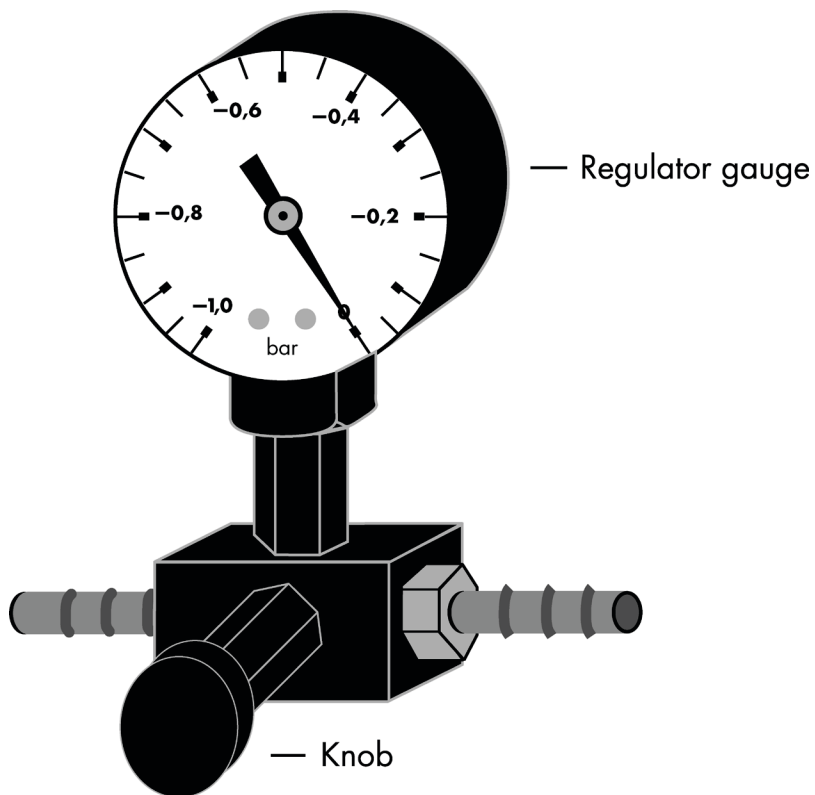

Figure 3. Schematic diagram of the Vacuum Regulator.

Setup of the QIAvac 24 Plus vacuum manifold

1. Connect the QIAvac 24 Plus to a vacuum source. If using the QIAvac Connecting System, connect the system to the manifold and vacuum source as described in Appendix A of the *QIAvac 24 Plus Handbook*.
2. Recommended: Insert a VacValve into each luer slot of the QIAvac 24 Plus that is to be used (see Figure 4, page 30).
VacValves should be used if flow rates of samples differ significantly to ensure consistent vacuum.
3. Insert a VacConnector into each VacValve (see Figure 4) or directly into each luer slot of the QIAvac 24 Plus that is to be used. Close unused luer slots with luer plugs or close the inserted VacValve.
Perform this step directly before starting the purification to avoid exposure of VacConnectors to potential contaminants in the air.
4. Place the QIAamp Mini spin columns into the VacConnectors on the manifold (see Figure 4).
5. For nucleic acid purification, follow the instructions in the vacuum protocol. Discard the VacConnectors appropriately after use.
Leave the lid of the QIAamp Mini spin column open while applying vacuum. Switch off the vacuum between steps to ensure that a consistent, even vacuum is applied during processing. For faster vacuum release, a vacuum regulator should be used (see Figure 3, page 28).

Note: Each VacValve can be closed individually when the sample is completely drawn through the spin column, allowing parallel processing of samples of different volumes or viscosities.

6. After processing samples, clean the QIAvac 24 Plus (see “Cleaning and Decontaminating the QIAvac 24 Plus” in the *QIAvac 24 Plus Handbook*).

Note: Buffers AVL and AW1 used in QIAamp DSP Viral RNA Mini procedure are not compatible with disinfecting agents containing bleach. See page 17 for safety information.

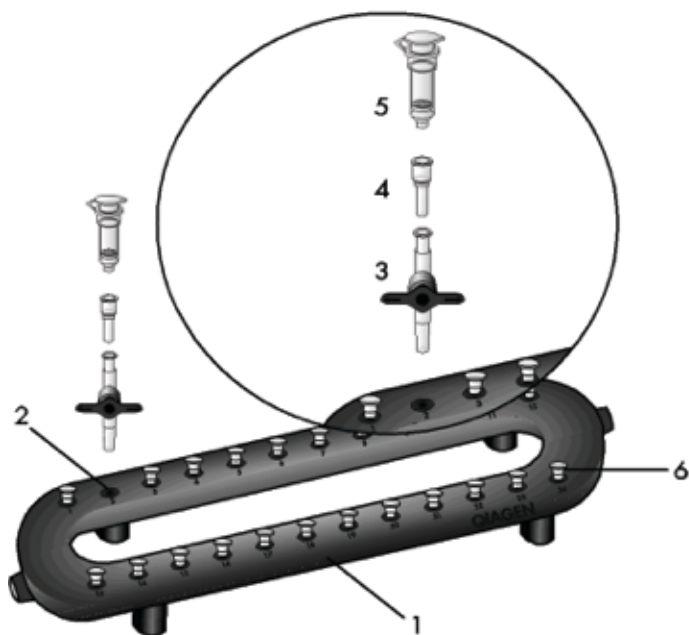

Figure 4. Setting up the QIAvac 24 Plus with QIAamp Mini spin columns using VacValves and VacConnectors.

- | | |
|------------------------------------|------------------------------------|
| 1. QIAvac 24 Plus vacuum manifold | 4. VacConnector* |
| 2. Luer slot of the QIAvac 24 Plus | 5. QIAamp Mini spin column |
| 3. VacValve (optional)* | 6. Luer slot closed with luer plug |
- * Must be purchased separately.

Centrifugation

Centrifugation of QIAamp Mini spin columns is performed at approximately 6000 x *g* to reduce centrifuge noise. Centrifugation at full speed will not improve RNA yields. Centrifugation at lower speeds for lysate loading and the first wash step is also acceptable, provided that the complete solution is transferred through the membrane. At the second wash step centrifugation at full speed is strongly recommended.

All centrifugation steps should be carried out at room temperature.

Protocol: Sample concentration

Plasma, serum, urine, cerebrospinal fluid, bone marrow, and other body fluids often have very low viral titers. In these cases, concentrating samples of up to 3.5 ml to a final volume of 140 μ l is recommended.

Important point before starting

- Use centrifugal microconcentrators such as Microsep 100 (Filtron: 3.5 ml, cat. no. OD100C40), Ultrafree®-CL (Millipore: 2 ml, cat. no. UFC4 THK 25), or equivalent from other suppliers.

Procedure

1. Apply up to 3.5 ml of sample to the microconcentrator following the manufacturer's instructions.
2. Centrifuge according to manufacturer's instructions to a final volume of 140 μ l.
Some samples, plasma in particular, may be difficult to concentrate to 140 μ l due to high viscosity. Centrifugation for up to 6 h may be necessary.
3. Pipet 140 μ l of concentrated sample into a 1.5 ml microcentrifuge tube, and follow the QIAamp DSP Viral RNA Spin Protocol on page 32.

Protocol: Purification of viral RNA using a microcentrifuge or the QIAcube/QIAcube Connect MDx

For purification of viral RNA from 140 µl plasma, serum, urine, cell culture media, or cell-free body fluids using a microcentrifuge or automated on the QIAcube or QIAcube Connect MDx. Larger starting volumes, up to 560 µl (in multiples of 140 µl), can be processed by increasing the initial volumes proportionally and loading the QIAamp Mini spin column multiple times, as described below in the protocol. Some samples with very low viral titers should be concentrated before the purification procedure; see "Protocol: Sample concentration" (page 31).

Important points before starting

- Read "Procedure" (pages 21–28) before starting the protocol.
- All centrifugation steps are carried out at room temperature (15–25°C).
- Automated processing of 2–10 or 12 samples can be performed on the QIAcube/QIAcube Connect MDx.
- For automation follow the instructions from the Protocol Sheets (QIAcube) or on the software screen (QIAcube Connect MDx) and refer to the appropriate user manuals (for the QIAcube and the QIAcube Connect MDx).

Things to do before starting

- Equilibrate samples to room temperature.
- Equilibrate Buffer AVE to room temperature for elution in step 11.
- Check that Buffer AW1 and Buffer AW2 have been prepared according to the instructions on page 25.
- Manual procedure only: add carrier RNA reconstituted in Buffer AVE to Buffer AVL according to instructions on page 22.

Procedure

- For the manual procedure with a microcentrifuge, follow steps 1–11.
 - This procedure can be automated in two different versions:
 - Standard: full automation using 140 μ L of sample (starting from step 1)
 - Manual Lysis: partly automated with off-board manual lysis (starting after step 4)
1. Pipet 560 μ l of prepared Buffer AVL containing carrier RNA into a lysis tube (LT).

If the sample volume is larger than 140 μ l, increase the amount of Buffer AVL–carrier RNA proportionally (e.g., a 280 μ l sample will require 1120 μ l Buffer AVL–carrier RNA) and use a larger tube.
 2. Add 140 μ l plasma, serum, urine, cell-culture supernatant, or cell-free body fluid to the Buffer AVL–carrier RNA in the lysis tube (LT). Mix by pulse-vortexing for 15 s.

To ensure efficient lysis, it is essential that the sample is mixed thoroughly with Buffer AVL to yield a homogeneous solution. Frozen samples that have only been thawed once can also be used.
 3. Incubate at room temperature for 10 min \pm 1 min.

Viral particle lysis is complete after lysis for 10 min at room temperature.
 4. Briefly centrifuge the lysis tube (LT) to remove drops from the inside of the lid.

Note: If manual lysis (steps 1–4) was done off-board, the following steps (steps 5–11) can be automated on the QIAcube or QIAcube Connect MDx following the (screen) instructions for protocol Manual Lysis.
 5. Add 560 μ l ethanol (96–100%) to the sample, and mix by pulse-vortexing for \geq 15 s. After mixing, briefly centrifuge the tube to remove drops from inside the lid.

Only ethanol should be used since other alcohols may result in reduced RNA yield and purity. Do not use denatured alcohol, which contains other substances such as methanol or methylethylketone. If the sample volume is greater than 140 μ l, increase the amount of ethanol proportionally (e.g., a 280 μ l sample will require 1120 μ l of ethanol). In order to ensure efficient binding, it is essential that the sample is mixed thoroughly with the ethanol to yield a homogeneous solution.

-
- Carefully apply 630 μ l of the solution from step 5 to the QIAamp Mini spin column (in a wash tube (WT)) without wetting the rim. Close the cap, and centrifuge at approximately 6000 $\times g$ for ≥ 1 min. Place the QIAamp Mini spin column into a clean 2 ml wash tube (WT), and discard the wash tube containing the filtrate.

Close each spin column in order to avoid cross-contamination during centrifugation.

Centrifugation is performed at approximately 6000 $\times g$ in order to limit microcentrifuge noise. Centrifugation at full speed will not affect the yield or purity of the viral RNA. If the solution has not completely passed through the membrane, centrifuge again at a higher speed until all of the solution has passed through.

- Carefully open the QIAamp Mini spin column, and repeat step 6.

Repeat this step until all of the lysate has been loaded onto the spin column.

- Carefully open the QIAamp Mini spin column, and add 500 μ l Buffer AW1. Close the cap, and centrifuge at approximately 6000 $\times g$ for ≥ 1 min. Place the QIAamp Mini spin column in a clean 2 ml wash tube (WT), and discard the wash tube containing the filtrate.

It is not necessary to increase the volume of Buffer AW1 even if the original sample volume was larger than 140 μ l.

- Carefully open the QIAamp Mini spin column, and add 500 μ l Buffer AW2. Close the cap and centrifuge at full speed (approximately 20,000 $\times g$) for 3 min \pm 30 s.

- Place the QIAamp Mini spin column in a new 2 ml wash tube (WT), and discard the wash tube containing the filtrate. Centrifuge at full speed for 1 min.

- Place the QIAamp Mini spin column in a clean elution tube (ET). Discard the wash tube containing the filtrate. Carefully open the QIAamp Mini spin column and add 60 μ l of Buffer AVE equilibrated to room temperature. Close the cap, and incubate at room temperature for ≥ 1 min.

Centrifuge at approximately 6000 $\times g$ for ≥ 1 min.

Important Note: In case of all automated procedures, remove the eluates from the instrument directly after the run finished and store them properly.

Protocol: Purification of viral RNA (vacuum protocol)

This protocol is for purification of viral RNA from 140 µl plasma, serum, urine, cell culture media, or cell-free body fluids using the QIAvac 24 Plus or equivalent vacuum manifold. Larger starting volumes, up to 560 µl (in multiples of 140 µl), can be processed by increasing the initial volumes proportionally and loading the QIAamp Mini spin column multiple times, as described below in the protocol. Some samples with very low viral titers should be concentrated before the purification procedure; see "Protocol: Sample concentration" (page 31).

Important points before starting

- Read "Procedure" (pages 21–28) before starting the protocol.
- All centrifugation steps are carried out at room temperature (15–25°C).

Things to do before starting

- Equilibrate samples to room temperature.
- Equilibrate Buffer AVE to room temperature for elution in step 14.
- Check that Buffer AW1 and Buffer AW2 have been prepared according to the instructions on page 25.
- Add carrier RNA reconstituted in Buffer AVE to Buffer AVL according to instructions on page 22.
- For processing using VacConnectors and VacValves, set up the QIAvac 24 Plus as described on page 29.

Procedure

1. Pipet 560 µl of prepared Buffer AVL containing carrier RNA into a lysis tube (LT).

If the sample volume is larger than 140 µl, increase the amount of Buffer AVL–carrier RNA proportionally (e.g., a 280 µl sample will require 1120 µl Buffer AVL–carrier RNA) and use a larger tube.

2. Add 140 μ l plasma, serum, urine, cell-culture supernatant, or cell-free body fluid to the Buffer AVL carrier RNA in the lysis tube (LT). Mix by pulse-vortexing for ≥ 15 s.

To ensure efficient lysis, it is essential that the sample is mixed thoroughly with Buffer AVL to yield a homogeneous solution. Frozen samples that have only been thawed once can also be used.

3. Incubate at room temperature for 10 min \pm 1 min.

Viral particle lysis is complete after lysis for 10 min \pm 1 min at room temperature.

4. Briefly centrifuge the tube to remove drops from the inside of the lid.

5. Add 560 μ l ethanol (96–100%) to the sample, and mix by pulse-vortexing for ≥ 15 s.

After mixing, briefly centrifuge the tube to remove drops from inside the lid. Insert a QIAamp Mini spin column into the VacConnector on the QIAvac 24 Plus vacuum manifold.

Only ethanol should be used since other alcohols may result in reduced yield and purity of the RNA. Do not use denatured alcohol, which contains other substances such as methanol or methylethylketone. In order to ensure efficient binding, it is essential that the sample is mixed thoroughly with the ethanol to yield a homogeneous solution. The collection tube from the blister pack can be saved for the centrifugation in step 13.

6. Make sure that the main vacuum valve (between the vacuum pump and the vacuum manifold) and the screw cap valve (on the end of the QIAvac 24 Plus vacuum manifold) are closed. Switch on the vacuum pump by pressing the power switch.

The vacuum is applied only to the connecting system (if used) and not to the vacuum manifold.

Note: For fast and convenient release of the vacuum pressure, the QIAvac Connecting System or the Vacuum Regulator should be used, see “Materials Required but Not Provided” (page 15).

7. Carefully apply 630 μ l of the lysate from step 5 into the QIAamp Mini spin column without wetting the rim. Avoid touching the QIAamp Mini spin column membrane with the pipette tip.

8. Open the main vacuum valve. Be sure to leave the lid of the QIAamp Mini spin column open while applying vacuum. After all lysates have been drawn through the QIAamp

Mini spin column, close the main vacuum valve and open the screw cap valve to vent the manifold. Close the screw cap valve after the vacuum is released from the manifold.

After closing the main vacuum valve, the vacuum is applied only to the connecting system (if used) and not the vacuum manifold. If the lysates from individual samples have not completely passed through the membrane despite the VacValves of all other QIAamp Mini spin columns being closed, place the QIAamp Mini spin column into a clean 2 ml wash tube (WT), close the cap, and centrifuge at full speed for 3 min or until it has completely passed through.

Continue with steps 7–11 of the spin protocol on page 34 to finish the procedure.

Centrifugation is performed at approximately 6000 x *g* in order to limit microcentrifuge noise. Centrifugation at full speed will not affect the yield or purity of viral RNA.

9. Apply 750 µl Buffer AW1 to the QIAamp Mini spin column without wetting the rim. Avoid touching the QIAamp Mini spin column membrane with the pipette tip.
10. Open the main vacuum valve. After all Buffer AW1 has been drawn through the QIAamp Mini spin column, close the main vacuum valve and open the screw cap valve to vent the manifold. Close the screw cap valve after the vacuum is released from the manifold.
11. Apply 750 µl Buffer AW2 to the QIAamp Mini spin column without wetting the rim. Avoid touching the QIAamp Mini spin column membrane with the pipette tip. Leave the lid of the column open.
12. Open the main vacuum valve. After all Buffer AW2 has been drawn through the QIAamp Mini spin column, close the main vacuum valve and open the screw cap valve to vent the manifold. Close the screw cap valve after the vacuum is released from the manifold.
13. Close the lid of the QIAamp Mini spin column. Remove it from the vacuum manifold and discard the VacConnector. Place the QIAamp Mini spin column in a clean 2 ml wash tube (WT) saved from step 5, and centrifuge at full speed for 1 min to dry the membrane completely.
14. Place the QIAamp Mini spin column into a clean elution tube (ET). Discard the collection tube containing the filtrate. Carefully open the QIAamp Mini spin column. Add 60 µl Buffer AVE equilibrated to room temperature. Close the cap, and incubate at room temperature for 1 min. Centrifuge at approximately 6000 x *g* for ≥1 min.

Quality Control

In accordance with QIAGEN's ISO-certified Quality Management System, each lot of QIAamp DSP Viral RNA Mini Kits is tested against predetermined specifications to ensure consistent product quality.

Limitations













The system performance has been established using plasma and serum samples, cell-free body fluids, and cell-culture supernatants for isolation of viral RNA.





It is the user's responsibility to validate system performance for any procedures used in their laboratory, which are not covered by the QIAGEN performance studies. To minimize the risk of a negative impact on the diagnostic results, adequate controls for downstream applications should be used. For further validation, the guidelines of the International Conference on Harmonization of Technical Requirements (ICH) in *ICH Q2(R1) Validation Of Analytical Procedures: Text And Methodology* are recommended.

Any diagnostic results that are generated must be interpreted in conjunction with other clinical or laboratory findings.

Symbols

The following symbols may appear in the instructions for use or on the packaging and labeling:

Symbol	Symbol definition
	Contains reagents sufficient for <N> reactions
	Use by
	In vitro diagnostic medical device
	Upon arrival
	Open on delivery; store QIAamp Mini Spin Columns at 2–8°C
	Catalog number
	Lot number
	Material number (i.e., component labeling)
	Components
	Volume
	Adding
	Temperature limitation
	Manufacturer

Symbol	Symbol definition
	Consult instructions for use
	Write down current date after adding ethanol to the bottle
EtOH	Ethanol
CONT	Contains
LYOPH	Lyophilized
RCNS	Reconstitute in
→	Leads to
GuHCl	Guanidine hydrochloride
GITC	Guanidine thiocyanate
GTIN	Global Trade Item Number
NUM	Number
Rn	R is for revision of the Instructions for Use and n is the revision number
	Keep away from sunlight
	Warning/caution

Contact Information

For technical assistance and more information, please see our Technical Support Center at **www.qiagen.com/Support**, call 800-362-7737 or contact one of the QIAGEN Technical Service Departments or local distributors (see back cover or visit **www.qiagen.com**).

Appendix

Handling RNA

Ribonucleases (RNases) are very stable and active enzymes that generally do not require cofactors to function. Since RNases are difficult to inactivate and only minute amounts are sufficient to destroy RNA, do not use any plasticware or glassware without first eliminating possible RNase contamination. Great care should be taken to avoid inadvertently introducing RNases into the RNA sample during or after the purification procedure. In order to create and maintain an RNase-free environment, the following precautions must be taken during pretreatment and use of disposable and non-disposable vessels and solutions while working with RNA.

General handling

Proper microbiological, aseptic technique should always be used when working with RNA. Hands and dust particles may carry bacteria and molds and are the most common sources of RNase contamination. Always wear latex or vinyl gloves while handling reagents and RNA samples to prevent RNase contamination from the surface of the skin or from dusty laboratory equipment. Change gloves frequently and keep tubes closed whenever possible. During the procedure, work quickly to avoid degradation of RNA by endogenous or residual RNases.

Disposable plasticware

The use of sterile, disposable polypropylene tubes is recommended throughout the procedure. These tubes are generally RNase-free and do not require pretreatment to inactivate RNases.

Non-disposable plasticware

Non-disposable plasticware should be treated before use to ensure that it is RNase-free. Plasticware should be thoroughly rinsed with 0.1 M NaOH,* 1 mM EDTA* followed by RNase-free water (see "Solutions", page 43). Alternatively, chloroform resistant plasticware can be rinsed with chloroform* to inactivate RNases.

* When working with chemicals, always wear a suitable lab coat, disposable gloves, and protective goggles. For more information, consult the appropriate safety data sheets (SDSs) available from the product supplier.

Glassware

Glassware should be treated before use to ensure that it is RNase-free. Glassware used for RNA work should be cleaned with detergent,* thoroughly rinsed, and oven baked at >240°C for four or more hours (overnight, if more convenient) before use. Autoclaving alone will not fully inactivate many RNases. Oven baking will inactivate ribonucleases. Alternatively, glassware can be treated with DEPC* (diethylpyrocarbonate). Rinse the glassware with 0.1% DEPC (0.1% in water) overnight (12 hours) at 37°C, and then autoclave or heat to 100°C for 15 minutes to remove residual DEPC.

Note: Corex® tubes should be rendered RNase-free by treatment with DEPC and not by baking. This will reduce the failure rate of this type of tube during centrifugation.

Electrophoresis tanks

Electrophoresis tanks should be cleaned with detergent solution (e.g., 0.5% SDS),* rinsed with water, dried with ethanol,*† and then filled with a solution of 3% H₂O₂.* After 10 minutes at room temperature, the electrophoresis tanks should be rinsed thoroughly with RNase-free water.

Solutions

Solutions (water and other solutions)* should be treated with 0.1% DEPC. DEPC will react with primary amines and cannot be used directly to treat Tris buffers.* DEPC is highly unstable in the presence of Tris buffers and decomposes rapidly into ethanol and CO₂. When preparing Tris buffers, treat water with DEPC first, and then dissolve Tris to make the appropriate buffer.

* When working with chemicals, always wear a suitable lab coat, disposable gloves, and protective goggles. For more information, consult the appropriate safety data sheets (SDSs) available from the product supplier.

† Plastics used for some electrophoresis tanks are not resistant to ethanol. Take proper care and check the suppliers' instructions.

DEPC is a strong, but not absolute, inhibitor of RNases. It is commonly used at a concentration of 0.1% to inactivate RNases on glass or plasticware or to create RNase-free solutions and water. DEPC inactivates RNases by covalent modification. Trace amounts of DEPC will modify purine residues in RNA by carbethoxylation. Carbethoxylated RNA is translated with very low efficiency in cell-free systems. However, its ability to form DNA:RNA or RNA:RNA hybrids is not seriously affected unless a large fraction of the purine residues have been modified. Residual DEPC must always be removed from solutions or vessels by autoclaving or heating to 100°C for 15 minutes.

Add 0.1 ml DEPC to 100 ml of the solution to be treated. Shake vigorously to bring the DEPC into solution, or let the solution bake for 12 hours at 37°C. Autoclave for 15 minutes to remove any trace of DEPC. It may be desirable to test water sources for the presence of contaminating RNases since many sources of distilled water are free of RNase activity.

Note: QIAamp DSP Viral RNA buffers are not rendered RNase-free by DEPC treatment and are therefore free of any DEPC contamination.

Ordering Information

Product	Contents	Cat. no.
QIAamp DSP Viral RNA Mini Kit (50)	For 50 RNA preps: QIAamp Mini Spin Columns, Carrier RNA, Collection Tubes (2 ml), and RNase-free Buffers	61904
Related products		
QIAcube Connect MDx*	Instrument and 1-year warranty on parts and labor	9003070
Accessories		
QIAvac 24 Plus vacuum manifold	Vacuum manifold for processing 1–24 spin columns: includes QIAvac 24 Plus Vacuum Manifold, Luer Plugs, Quick Couplings	19413
VacConnectors	500 disposable connectors for use with QIAamp spin columns on luer connectors	19407
Vacuum Regulator	For use with QIAvac manifolds	19530
Vacuum Pump	Universal vacuum pump	84010
VacValves	24 valves for use with the QIAvac 24 and QIAvac 24 Plus	19408
QIAvac Connecting System	System to connect vacuum manifold with vacuum pump: includes Tray, Waste Bottles, Tubing, Couplings, Valve, Gauge, 24 VacValves	19419
Rotor Adapters	For 240 preps: 240 Disposable Rotor Adapters and 240 Elution Tubes (1.5 ml); for use with the QIAcube	990394

Product	Contents	Cat. no.
Rotor Adapter Holder	Holder for 12 disposable rotor adapters; for use with the QIAcube	990392
Sample Tubes CB	1000 conical screw-cap tubes without skirted base (2 ml) for use with the QIAcube and QIAcube Connect	990382
Shaker Rack Plugs	For loading the QIAcube shaker rack	9017854
Reagent Bottles, 30 ml	Reagent Bottles (30 ml) with lids; pack of 6; for use with the QIAcube	990393
Filter-Tips, 1000 µl	Disposable Filter-Tips, racked; (8 x 128). For use with the QIAcube	990352

* The QIAcube Connect MDx is not available in all countries. For further details please contact QIAGEN Technical Service.

For up-to-date licensing information and product-specific disclaimers, see the respective QIAGEN kit handbook or user manual. QIAGEN kit handbooks and user manuals are available at www.qiagen.com or can be requested from QIAGEN Technical Services or your local distributor.

Document Revision History

Revision	Description
R6, 01/2021	<p>Updated the following sections: "Automated viral RNA purification on the QIAcube/QIAcube Connect MDx", "Materials Required but Not Provided", "Warnings and Precautions", "Protocol: Purification of viral RNA using a microcentrifuge or the QIAcube/QIAcube Connect MDx", "Symbols", and "Ordering Information" sections.</p> <p>Removed the "References" section.</p> <p>Inserted a new figure (image of the QIAcube Connect MDx)</p> <p>Added references to the QIAcube Connect MDx and its accessories.</p> <p>Editorial and layout changes.</p>

This page is deliberately left blank.

Limited License Agreement for QIAamp DSP Viral RNA Mini Kit

Use of this product signifies the agreement of any purchaser or user of the product to the following terms:

1. The product may be used solely in accordance with the protocols provided with the product and this handbook and for use with components contained in the panel only. QIAGEN grants no license under any of its intellectual property to use or incorporate the enclosed components of this panel with any components not included within this panel except as described in the protocols provided with the product, this handbook, and additional protocols available at www.qiagen.com. Some of these additional protocols have been provided by QIAGEN users for QIAGEN users. These protocols have not been thoroughly tested or optimized by QIAGEN. QIAGEN neither guarantees them nor warrants that they do not infringe the rights of third-parties.
2. Other than expressly stated licenses, QIAGEN makes no warranty that this panel and/or its use(s) do not infringe the rights of third-parties.
3. This panel and its components are licensed for one-time use and may not be reused, refurbished, or resold.
4. QIAGEN specifically disclaims any other licenses, expressed or implied other than those expressly stated.
5. The purchaser and user of the panel agree not to take or permit anyone else to take any steps that could lead to or facilitate any acts prohibited above. QIAGEN may enforce the prohibitions of this Limited License Agreement in any Court, and shall recover all its investigative and Court costs, including attorney fees, in any action to enforce this Limited License Agreement or any of its intellectual property rights relating to the panel and/or its components.

For updated license terms, see www.qiagen.com.

Trademarks: QIAGEN®, QIAamp®, QIAcube® (QIAGEN Group); Corex® (Corning, Inc.); Tween® (ICI Americas Inc.); UltraFree® (Millipore Corporation); Sarstedt® (Sarstedt AG & Co.). Registered names, trademarks, etc. used in this document, even when not specifically marked as such, are not to be considered unprotected by law.

01/2021 HB-0418-008 1122786 © 2021 QIAGEN, all rights reserved.

Ordering www.qiagen.com/shop | Technical Support support.qiagen.com | Website www.qiagen.com